

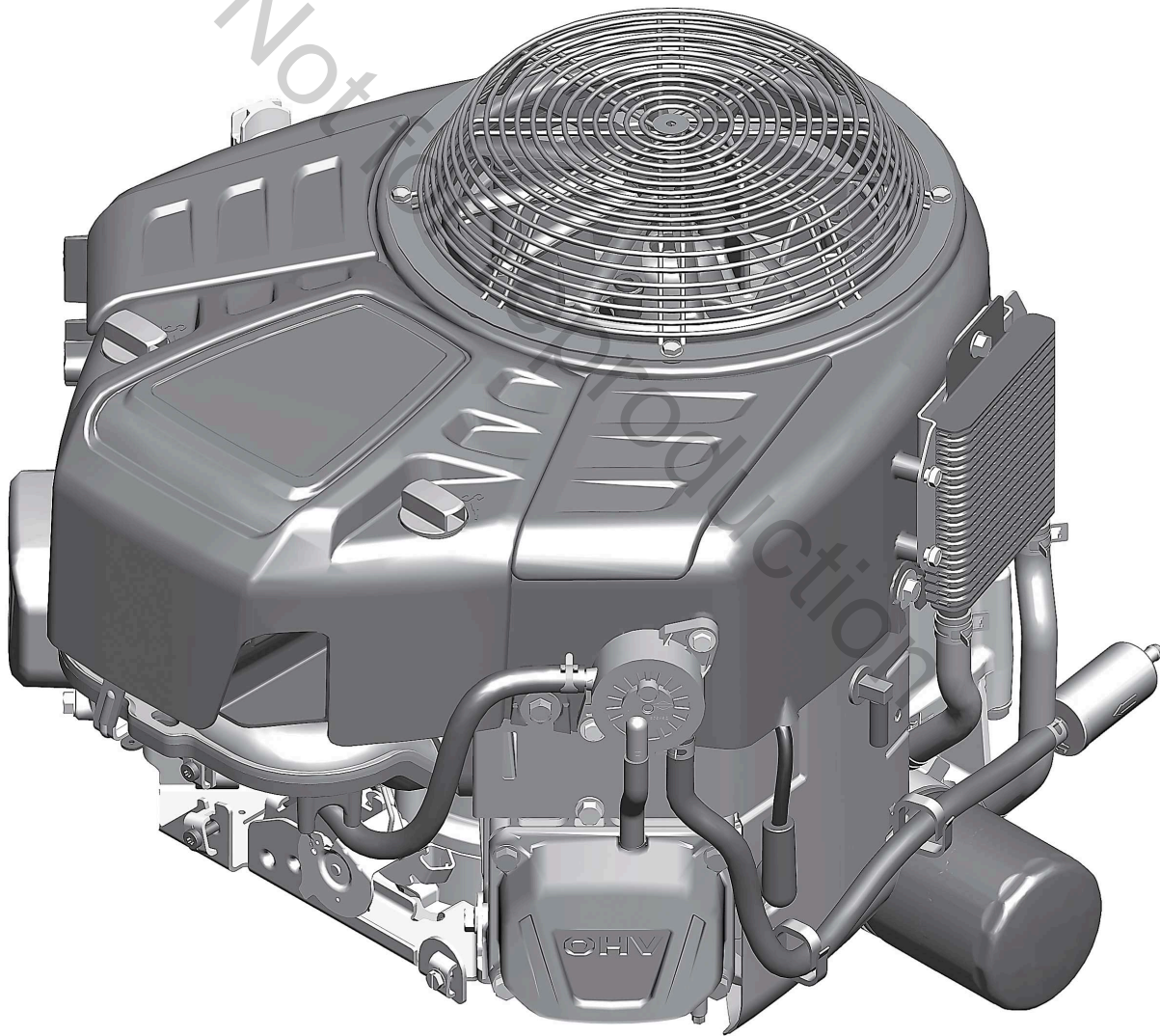

44J677, 44X977

en Operator's Manual

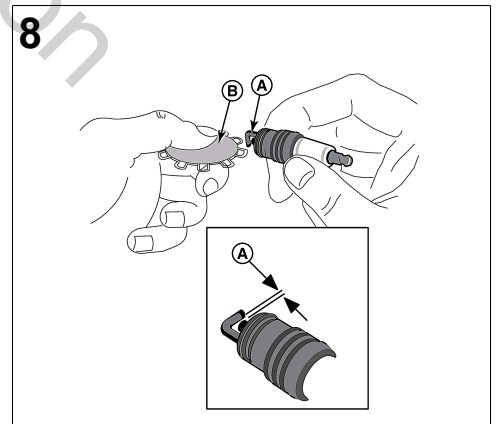

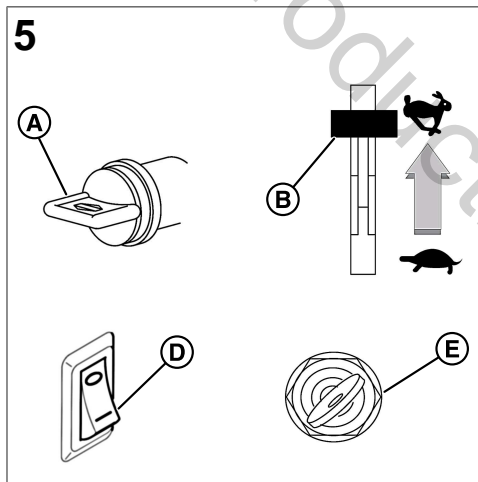
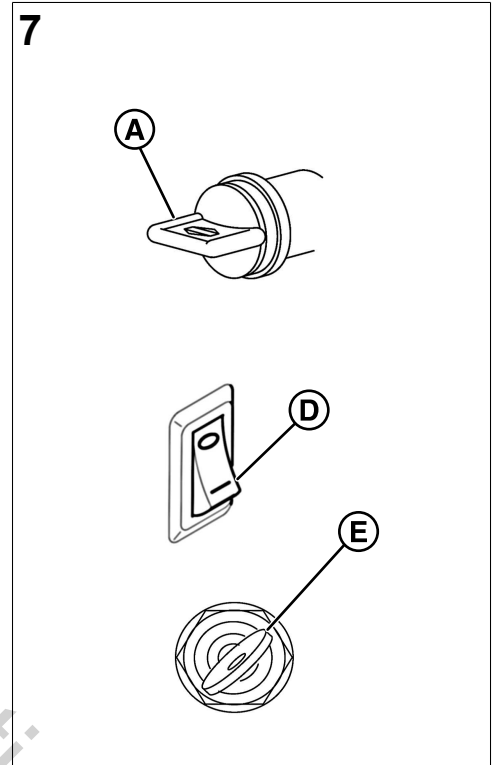
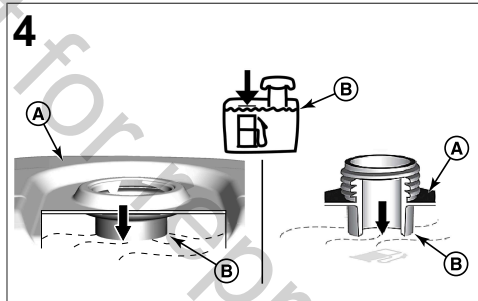
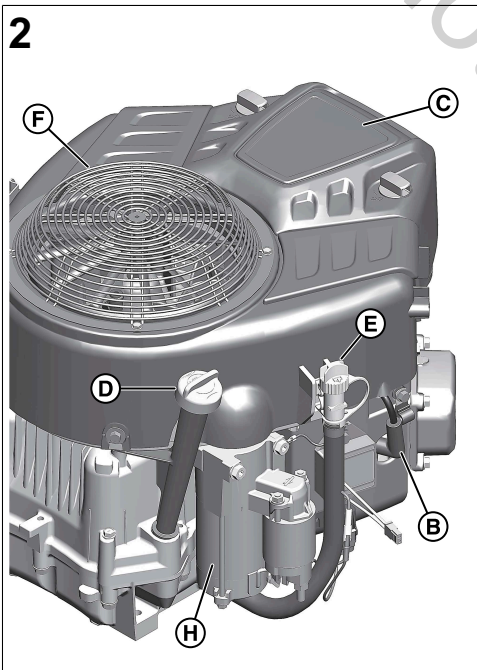
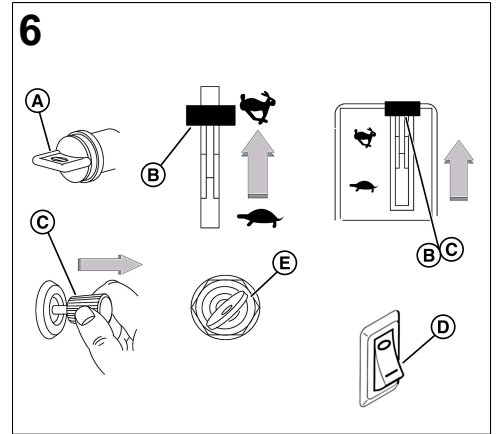
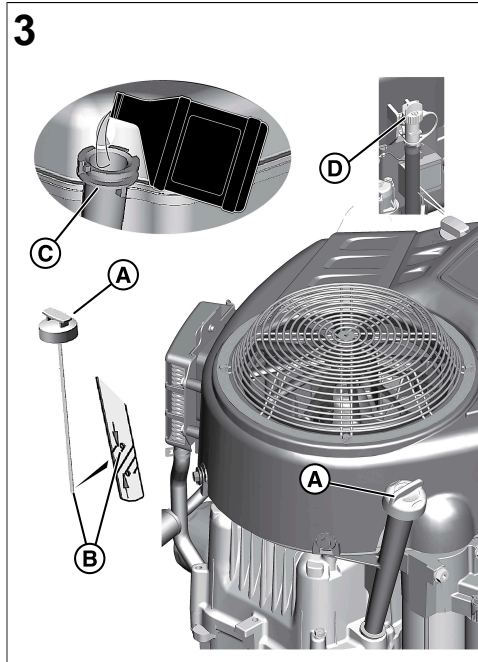
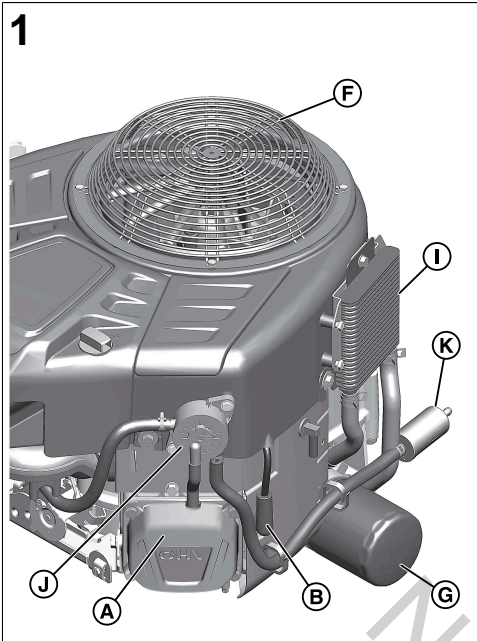

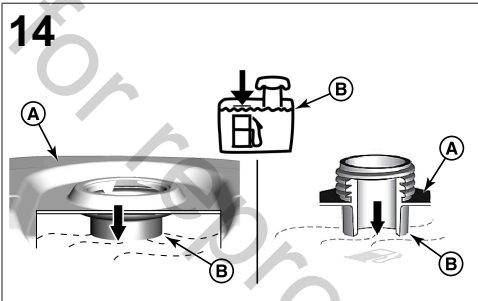
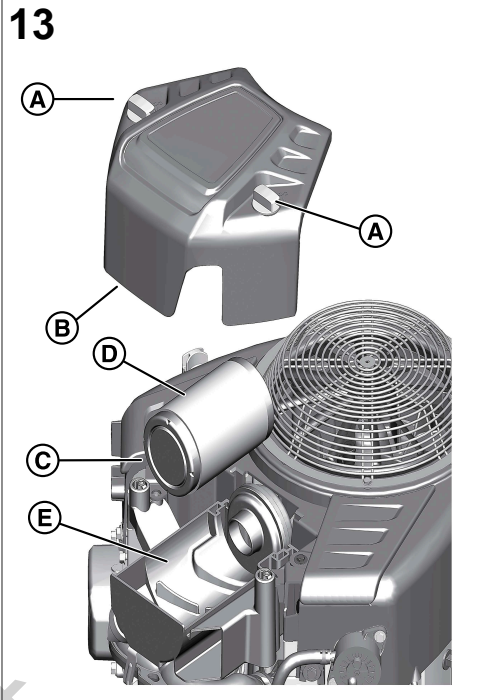
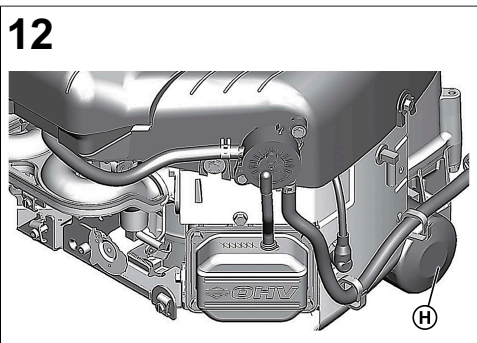
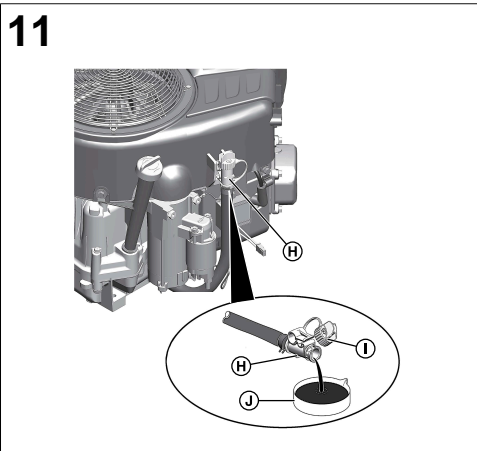
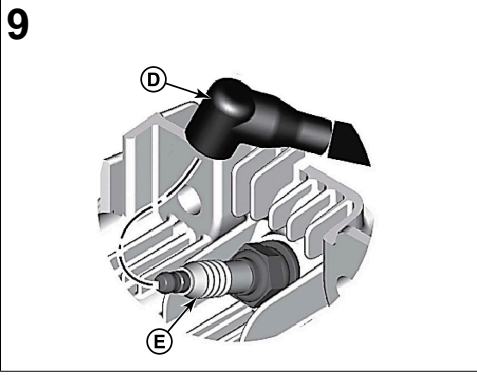

General Information



This manual contains the safety information about the hazards and risks related to the engine and how to prevent them. It also contains the correct operation and maintenance of this engine. It is important that you read, understand, and obey these instructions. **Keep this manual for future reference.**

NOTE: The figures and illustrations in this manual are for information only and can be different from your model. Use the figures that align with your engine configuration. If it is necessary, speak to an Authorized Service Dealer.

Record the date of purchase, engine model, type, trim, and the engine serial number for replacement parts. These numbers are on your engine. Refer to the **Features and Controls** section.

Date of Purchase	
Engine Model - Type - Trim	
Engine Serial Number	

European Office Contact Information

For questions related to European emissions, contact our European office at:

Max-Born-Straße 2, 68519 Viernheim, Germany.

European Union (EU) Stage V (5): Carbon Dioxide (CO₂) Values

Enter CO₂ in the search window on BriggsandStratton.com to find carbon dioxide values of Briggs & Stratton EU Type-Approval Certificate engines.

Recycling Information

		Recycle all cartons, boxes, used oil, and batteries as specified by government regulations.
--	--	---------------------------------------------------------------------------------------------

Operator Safety

Safety Alert Symbol and Signal Words



The safety alert symbol identifies safety information about hazards that could result in personal injury. A signal word (**DANGER**, **WARNING**, or **CAUTION**) is used to indicate the likelihood and the potential severity of injury. In addition, a hazard symbol is used to represent the type of hazard.

DANGER indicates a hazard which, if not avoided, **will** result in death or serious injury.

WARNING indicates a hazard which, if not avoided, **could** result in death or serious injury.

CAUTION indicates a hazard which, if not avoided, **could** result in minor or moderate injury.

NOTICE indicates information considered important but not hazard-related.

Hazard Symbols and Meanings

	Safety information about hazards that can result in personal injury.		Read and understand the Operator's Manual before operating or servicing the unit.
	Fire Hazard		Explosion Hazard
	Shock Hazard		Toxic Fume Hazard
	Hot Surface Hazard		Kickback Hazard

	Amputation Hazard - Moving Parts		Fuel Level - Maximum Do Not Overfill
--	----------------------------------	--	--------------------------------------

Safety Messages



WARNING

This product can expose you to chemicals including gasoline engine exhaust, which is known to the State of California to cause cancer, and carbon monoxide, which is known to the State of California to cause birth defects or other reproductive harm. For more information go to www.P65Warnings.ca.gov.



WARNING

Briggs & Stratton® Engines are not designed for and are not to be used to power: fun-karts; go-karts; children's, recreational, or sport all-terrain vehicles (ATVs); motorbikes; hovercraft; aircraft products; or vehicles used in competitive events not sanctioned by Briggs & Stratton. For information about competitive racing products, see www.briggsracing.com. For use with utility and side-by-side ATVs, please contact Briggs & Stratton Power Application Center, 1-866-927-3349. Incorrect engine use could result in serious injury or death.



WARNING

Fuel and its vapors are flammable and explosive. Fire or explosion could result in burns or death.

When you add fuel

- Stop the engine. Before you remove the fuel cap, wait a minimum of two (2) minutes to make sure that the engine is cool.
- Fill the fuel tank outdoors or in an area that has good airflow.
- Do not put too much fuel in the tank. For expansion of the fuel, do not fill above the bottom of the fuel tank neck.
- Keep fuel away from sparks, open flames, pilot lights, heat, and other ignition sources.
- Frequently examine the fuel lines, fuel tank, fuel cap, and connections for cracks or leaks. Replace damaged parts.
- If fuel spills, wait until it dries before you start the engine.

When you start the engine

- Make sure that the spark plug, muffler, fuel cap and air cleaner (if equipped) are correctly installed.
- Do not crank the engine with the spark plug removed.
- If the engine is flooded, set the choke (if equipped) to the OPEN or RUN position. Move the throttle (if equipped) to the FAST position and crank until the engine starts.
- If there is natural or LP gas leakage in the area, do not start the engine.
- Because vapors are flammable, do not use pressurized starter fluids.

When you operate the equipment

- Do not tilt the engine or the equipment at an angle which causes fuel to spill.
- Do not choke the carburetor (if equipped) to stop the engine.
- Do not start or operate the engine with the air cleaner (if equipped) or the air filter (if equipped) removed.

When you do maintenance

- If you drain the oil from the top oil fill tube, the fuel tank must be empty. If it is not empty, fuel leakage can occur and could result a fire or an explosion.
- During maintenance if it is necessary to tilt the unit, make sure that the fuel tank, if mounted on the engine, is empty and that the spark plug side is up. If the fuel tank is not empty, leakage can occur and could result a fire or an explosion.
- Frequently examine the fuel lines, fuel tank, fuel cap, and connections for cracks or leaks. Replace damaged parts.
- Do not change the governor spring, links or other parts to increase engine speed.
- Do not hit the flywheel with a hammer or hard object. This could result in failure of the flywheel during operation.
- Replacement parts must be of the same design and installed in the same position as the original parts. Other parts could result in damage or an injury.

When you move the location of equipment

- Make sure that the fuel tank is EMPTY or that the fuel shut-off valve is in the CLOSED position.

When fuel or equipment is in storage with fuel in the fuel tank

- Because pilot lights or other ignition sources can cause explosions, keep fuel or equipment away from furnaces, stoves, water heaters or other appliances that have pilot lights.



WARNING
Fuel and its vapors are flammable and explosive. Fire or explosion could result in burns or death.

Engine start-up causes spark that could result in a fire or explosion.

- If there is natural or LP gas leakage in the area, do not start the engine.
- Because vapors are flammable, do not use pressurized starter fluids.



WARNING
POISONOUS GAS HAZARD. Engine exhaust contains carbon monoxide, a poisonous gas that could kill you in minutes. Although you do not smell exhaust fumes, you could still be exposed to dangerous carbon monoxide gas. If you feel sick, dizzy, or weak while you use this product, get to fresh air **RIGHT AWAY**. See a doctor. You may have carbon monoxide poisoning.

- Carbon monoxide gas can collect in occupied spaces. To reduce the risk of carbon monoxide gas, **ONLY** operate this product outdoors and far away from windows, doors and vents.
- Install battery-operated carbon monoxide alarms or plug-in carbon monoxide alarms with battery back-up as specified by the manufacturer's instructions. Smoke alarms cannot sense carbon monoxide gas.
- **DO NOT** operate this product in homes, garages, basements, crawlspaces, sheds, or other closed spaces, even if you use fans or open doors and windows for ventilation. After the operation of this product, carbon monoxide can quickly collect in these spaces and stay for hours.
- **ALWAYS** put this product downwind and point the engine exhaust away from occupied spaces.



WARNING
Fast retraction of the starter cord (kickback) will pull your hand and arm to the engine faster than you can let go. Broken bones, fractures, bruises or sprains could result.

- To prevent kickback when you start the engine, pull the starter cord slowly until resistance is felt and then pull quickly.
- Before you start the engine, disconnect or remove all external equipment and engine loads.
- Make sure that direct-coupled equipment components, such as, but not limited to, blades, impellers, pulleys, and sprockets, are correctly attached.



WARNING
Rotating parts can entangle hands, feet, hair, clothing, or accessories and result in traumatic amputation or laceration.

- Operate equipment with the guards correctly installed.
- Keep hands and feet away from rotating parts.
- Remove jewelry and make sure that long hair is away from all rotating parts.
- Do not wear loose clothes or items that could become caught.



WARNING
During operation, the engine and muffler become hot. If you touch a hot engine, thermal burns can occur.

Combustible materials, such as leaves, grass and brush, can catch fire.

- Before you touch the engine or muffler, stop the engine and wait two (2) minutes. Make sure that the engine and muffler are safe to touch.
- Remove debris from the muffler and engine.

It is a violation of California Public Resource Code, Section 4442, to use or operate the engine on any forest-covered, brush-covered, or grass-covered land unless the exhaust system is equipped with a spark arrester, as defined in section 4442, maintained in effective working order. Other states or federal jurisdictions may have similar laws; reference Federal Regulation 36 CFR Part 261.52. Contact the original equipment manufacturer, retailer, or dealer to obtain a spark arrester designed for the exhaust system installed on this engine.



WARNING
Accidental engine spark can cause an electric shock, fire or explosion and could result in entanglement, traumatic amputation or laceration.

Before you make adjustments or repairs:

- Disconnect all spark plug wires and keep them away from the spark plugs.
- Disconnect the battery wire from the negative battery terminal (only engines with electric start).
- Use only the correct tools.

When you check for spark:

- Use an approved spark plug tester.
- Do not check for spark with the spark plug removed.



WARNING
Fuel vapors are flammable and explosive. Fire or explosion could result in burns or death.

If you smell gas

- Do not start the engine.
- Do not switch on electrical switches.
- Do not use a phone in the vicinity.
- Evacuate the area.
- Contact the gas supplier or the fire department.

Features and Controls

Engine Controls

Compare the callout letters in Figures 1 and 2 to the engine controls in the list that follows.

- A. Engine Identification Numbers **Model - Type - Trim**
- B. Spark Plug
- C. Air Cleaner
- D. Dipstick
- E. Quick Oil Drain
- F. Air Intake Grille
- G. Oil Filter
- H. Electric Starter
- I. Oil Cooler
- J. Fuel Pump
- K. Fuel Filter

Engine Control Symbols and Meanings

Engine Speed - FAST	Engine Speed - SLOW
Engine Speed - STOP	ON - OFF
Engine Start Choke CLOSED	Engine Start Choke OPEN
Fuel Cap Fuel Shut-off OPEN	Fuel Shut-off CLOSED

Operation

Oil Recommendations

Oil Capacity: Refer to the *Specifications* section.

We recommend the use of Briggs & Stratton® Warranty Certified oils for best performance. Other high-quality detergent oils are permitted if classified for service SF, SG, SH, SJ or higher. Do not use special additives.

Use the chart to select the best viscosity for the outdoor temperature range expected. Engines on most outdoor power equipment operate good with 5W-30 Synthetic oil. For equipment operated in hot temperatures, Vanguard® 15W-50 Synthetic oil gives the best protection.

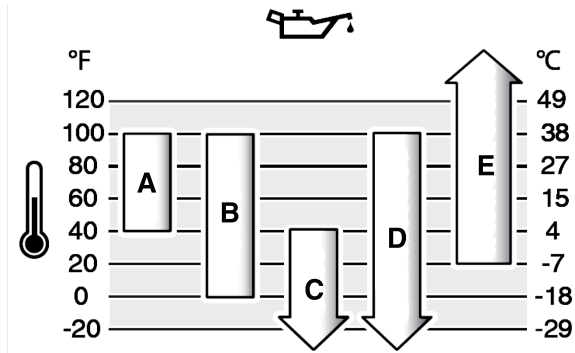

A	SAE 30 - Below 40 °F (4 °C) the use of SAE 30 will result in hard starting.
B	10W-30 - Above 80 °F (27 °C) the use of 10W-30 may cause increased oil consumption. Check the oil level frequently.
C	5W-30
D	Synthetic 5W-30
E	Vanguard® Synthetic 15W-50

Low Oil Protection System (if installed)

A low oil sensor is installed on some engines. If the oil is low, the sensor will show a warning light or stop the engine. Stop the engine and do the steps that follow before you start the engine.

- Make sure that the engine is level.
- Do an oil check. Refer to the **Check Oil Level** section.
- If the oil level is low, add the correct amount of oil. Start the engine and make sure that the warning light (if installed) does not come on.
- If the oil level is not low, do not start the engine. Contact a Briggs & Stratton Authorized Service Dealer to correct the oil problem.

Check Oil Level

NOTE: Before you add or check the oil, make sure that the engine is level.

NOTICE

This engine was shipped from Briggs & Stratton without oil. Equipment manufacturers or dealers could have added oil to the engine. Before you start the engine for the first time, make sure that the oil is at the correct level. Add oil as specified by the instructions in this manual. If you start the engine without oil, damage will occur and the engine will not be repaired under warranty.

1. Remove the dipstick (A, Figure 3). Remove all oil from the dipstick with a clean cloth.
2. Install and tighten the dipstick (A, Figure 3).
3. Remove the dipstick and check the oil level. The correct oil level is at the top of the full indicator (B, Figure 3) on the dipstick.
4. If oil level is low, open the oil fill (C, Figure 3). Slowly add oil into the oil remote tank (D). **DO NOT** add too much oil.

NOTE: Do not add oil at the quick oil drain (D, Figure 3), if equipped.

5. Install and tighten the dipstick (A, Figure 3).

Fuel Recommendations

Fuel must meet these requirements:

- Clean, fresh, unleaded gasoline.
- A minimum of 87 octane/87 AKI (91 RON). High altitude use, see below.
- Gasoline with up to 10% ethanol (gasohol) is permitted.

NOTICE

Do not use unapproved gasoline, such as E15 and E85. Do not mix oil in gasoline or change the engine to operate on alternate fuels. Use of unapproved fuels could result in damage to engine components, which will not be repaired under the warranty.

To protect the fuel system from gum formation, and corrosion, mix an alcohol-free fuel stabilizer and ethanol treatment into the fuel. Refer to the **Storage** section. All fuel is not the same. If start or performance problems occur, change fuel providers or brands. This engine is certified to operate on gasoline. The emissions control system for

carbureted engines is EM (Engine Modifications). The emissions control systems for engines with electronic fuel injection are ECM (Engine Control Module), MFI (Multiport Fuel Injection), TBI (Throttle Body Fuel Injection) and if equipped an O2S (Oxygen Sensor).

High Altitude

At altitudes over 5,000 feet (1524 meters), a minimum 85 octane/85 AKI (89 RON) gasoline is permitted.

For carbureted engines, high altitude adjustment is required to maintain performance. Operation without this adjustment will cause decreased performance, increased fuel consumption, and increased emissions. Contact a Briggs & Stratton Authorized Service Dealer for high altitude adjustment information. Operation of the engine at altitudes below 2,500 feet (762 meters) with the high altitude adjustment is not recommended.

For Electronic Fuel Injection (EFI) engines, no high altitude adjustment is necessary.

Add Fuel



WARNING

Fuel and its vapors are flammable and explosive. Fire or explosion could result in burns or death.

When you add fuel

- Stop the engine. Before you remove the fuel cap, wait a minimum of two (2) minutes to make sure that the engine is cool.
 - Fill the fuel tank outdoors or in an area that has good airflow.
 - Do not put too much fuel in the tank. For expansion of the fuel, do not fill above the bottom of the fuel tank neck.
 - Keep fuel away from sparks, open flames, pilot lights, heat, and other ignition sources.
 - Frequently examine the fuel lines, fuel tank, fuel cap, and connections for cracks or leaks. Replace damaged parts.
 - If fuel spills, wait until it dries before you start the engine.
1. Clean the fuel cap area of dirt and debris. Remove the fuel cap.
 2. Fill the fuel tank (A, Figure 4) with fuel. Because fuel will expand, do not fill above the bottom of the fuel tank neck (B).
 3. Install the fuel cap.

Start and Stop the Engine



WARNING

Fast retraction of the starter cord (kickback) will pull your hand and arm to the engine faster than you can let go. Broken bones, fractures, bruises or sprains could result.

- To prevent kickback when you start the engine, pull the starter cord slowly until resistance is felt and then pull quickly.
- Before you start the engine, disconnect or remove all external equipment and engine loads.
- Make sure that direct-coupled equipment components, such as, but not limited to, blades, impellers, pulleys, and sprockets, are correctly attached.



WARNING

Fuel and its vapors are flammable and explosive. Fire or explosion could result in burns or death.

When you start the engine

- Make sure that the spark plug, muffler, fuel cap and air cleaner (if equipped) are correctly installed.
- Do not crank the engine with the spark plug removed.
- If the engine is flooded, set the choke (if equipped) to the OPEN or RUN position. Move the throttle (if equipped) to the FAST position and crank until the engine starts.
- If there is natural or LP gas leakage in the area, do not start the engine.
- Because vapors are flammable, do not use pressurized starter fluids.



WARNING

POISONOUS GAS HAZARD. Engine exhaust contains carbon monoxide, a poisonous gas that could kill you in minutes. Although you do not smell exhaust fumes, you could still be exposed to dangerous carbon monoxide gas. If you feel sick, dizzy, or weak while you use this product, get to fresh air RIGHT AWAY. See a doctor. You may have carbon monoxide poisoning.

- Carbon monoxide gas can collect in occupied spaces. To reduce the risk of carbon monoxide gas, ONLY operate this product outdoors and far away from windows, doors and vents.
- Install battery-operated carbon monoxide alarms or plug-in carbon monoxide alarms with battery back-up as specified by the manufacturer's instructions. Smoke alarms cannot sense carbon monoxide gas.
- DO NOT operate this product in homes, garages, basements, crawlspaces, sheds, or other closed spaces, even if you use fans or open doors and windows for ventilation. After the operation of this product, carbon monoxide can quickly collect in these spaces and stay for hours.
- ALWAYS put this product downwind and point the engine exhaust away from occupied spaces.

NOTICE

This engine was shipped from Briggs & Stratton without oil. Equipment manufacturers or dealers could have added oil to the engine. Before you start the engine for the first time, make sure that the oil is at the correct level. Add oil as specified by the instructions in this manual. If you start the engine without oil, damage will occur and the engine will not be repaired under warranty.

Types of Start Systems

Before you start the engine, you must know the type of start system on your engine. Your engine has one of these types.

- **Electronic Fuel Injection (EFI) System:** This system does not have a choke or a primer.
- **Choke System:** This type of system has a choke to use in cool temperatures. Some models have a choke control, but other models have a combination choke and throttle choke. It does not have a primer.

NOTE: Your equipment can have remote controls. Refer to the equipment manual for location and operation of remote controls.

Electronic Fuel Injection (EFI) System

1. Check the engine oil. See the **Check Oil Level** section.
2. Make sure equipment drive controls, if equipped, are disengaged.
3. Move the fuel shut-off (A, Figure 5), if equipped, to the OPEN position.
4. Move the throttle control (B, Figure 5), if equipped, to the FAST position. Operate the engine in the FAST position.

NOTE: For models with Electronic Throttle Control, the throttle control does not have to be in a specified position.

5. Push the stop switch (D, Figure 5), if equipped, to the ON position.
6. Turn the electric start switch (E, Figure 5) to the ON or START position.

NOTICE To extend the life of the starter, use short start cycles (five seconds maximum). Wait one minute between start cycles.

If the engine does not start after 3 or 4 times, contact your local dealer or go to BRIGGSandSTRATTON.COM or call 1-800-444-7774.

Choke System

1. Check the engine oil. See **Check Oil Level** section.
2. Make sure that the equipment drive controls, if installed, are disengaged.
3. Move the fuel shut-off (A, Figure 6), if installed, to the OPEN position.
4. Move the throttle control (B, Figure 6), if installed, to the FAST position. Operate the engine in the FAST position.
5. Move the choke control (C, Figure 6), or the combination choke and throttle (B,C) to the CLOSED position.

NOTE: To start the engine with a dry fuel system, additional cranking time in the choke position will be required. This will give the fuel pump time to prime the fuel system.

6. Push the stop switch (D, Figure 6), if installed, to the ON position.
7. Turn the key switch (E, Figure 6) to the ON or START position.
8. If the engine starts but will not continue to operate, move the choke control (C, Figure 6) to the OPEN position to start the engine.

NOTICE To extend the life of the starter, use short start cycles (five seconds maximum). Wait one minute between start cycles.

9. As the engine warms, move the choke control (C, Figure 6) to the OPEN position.

If the engine does not start after 3 or 4 times, contact your local dealer or go to BRIGGSandSTRATTON.COM or call 1-800-444-7774.

Stop the Engine



WARNING

Fuel and its vapors are flammable and explosive. Fire or explosion could result in burns or death.

- Do not choke the carburetor (if equipped) to stop the engine.
1. **Stop Switch, if installed:** Move the stop switch (D, Figure 7) to the OFF position.
 2. **Key Switch, if installed:** Set the throttle control to the SLOW position. Turn the key switch (E, Figure 7) to the OFF position. Remove the key and keep it in a safe location out of reach of children.
 3. After the engine stops, move the fuel shut-off (A, Figure 7), if installed, to the CLOSED position.

Maintenance

Maintenance Information



WARNING

Fuel and its vapors are flammable and explosive. Fire or explosion could result in burns or death.

During maintenance if it is necessary to tilt the unit, make sure that the fuel tank, if mounted on the engine, is empty and that the spark plug side is up. If the fuel tank is not empty, leakage can occur and could result in a fire or an explosion. If the engine is tilted in a different direction, it will not easily start because of oil or fuel contamination of the air filter or the spark plug.



WARNING

Accidental engine spark can cause an electric shock, fire or explosion and could result in entanglement, traumatic amputation or laceration.

Before you make adjustments or repairs:

- Disconnect all spark plug wires and keep them away from the spark plugs.
- Disconnect the battery wire from the negative battery terminal (only engines with electric start).
- Use only the correct tools.

When you check for spark:

- Use an approved spark plug tester.
- Do not check for spark with the spark plug removed.



WARNING

All the components used to assemble this engine must stay in the initial position for correct operation. Damage or injury can occur if you use incorrect parts or you do not replace all parts on the engine.

- Replacement parts must be of the same design and installed in the same position as initial parts.
- If installed, do not change the governor spring, links, or other parts to increase the engine speed.

See a Briggs & Stratton Authorized Service Dealer for all maintenance and servicing of the engine and engine parts.

Emissions Control Service

For maintenance, replacement, or repair of emissions control devices and systems, contact a qualified off-road engine repair establishment or service technician. However, for "no charge" emissions control service, the work must be done by a factory authorized dealer. Refer to the Emissions Control Statements.

Maintenance Schedule

Before Each Use
<ul style="list-style-type: none"> • Check the engine oil level.
After Each Use
<ul style="list-style-type: none"> • Clean the finger guard / rotating screen. • Clean the area around the muffler and controls.
Intervals of 100 Hours

- Change the engine oil.
- Change the oil filter.
- Clean the air filter.
- Clean the oil cooler fins.
- Clean the air cooling system.
- Check, clean, re-gap spark plug.

Intervals of 125 Hours

- Change the air filter.

Intervals of 250 Hours

- Replace the spark plug.
- Check the valve clearance.

Intervals of 300 Hours

- Replace the fuel filter.

Intervals of 500 Hours

- Clean the air the cooling system. Remove the blower housing.

Electronic Fuel Injection (EFI) System

The EFI System monitors engine temperature, engine speed, and battery voltage for engine start-up and warm-up. There are no adjustments on the system. If start-up or operation problems occur, contact a Briggs & Stratton Authorized Service Dealer.

NOTICE Make sure to obey the steps that follow or damage to the EFI system could occur.

- DO NOT start the engine if the battery cables are loose.
- Turn the key to the OFF position before you disconnect, remove, and / or install the battery.
- DO NOT use a battery charger to start the engine.
- DO NOT disconnect the battery cables during engine operation.
- When you disconnect the battery cables, first connect the positive (+) cable, and then connect the negative (-) cable to the battery.
- When you charge the battery, turn the ignition switch to the OFF position, and disconnect the negative (-) battery cable from the battery.
- DO NOT spray water directly on the Electronic Control Module.

Carburetor and Engine Speed

Do not make adjustments to the carburetor, governor spring, linkages, or other parts to adjust the engine speed. If adjustments are necessary, contact a Briggs & Stratton Authorized Service Dealer for servicing.

NOTICE

The equipment manufacturer specifies the maximum speed for the engine as installed on the equipment. Do not exceed this speed. If you are not sure what the equipment maximum speed is, or what the engine speed is set to from the factory, contact a Briggs & Stratton Authorized Service Dealer for assistance. For safe and correct operation of the equipment, the engine speed should only be adjusted by a qualified service technician.

Servicing the Spark Plug

Check the spark plug gap (A, Figure 8) with a wire gauge (B). If necessary, set the spark plug gap. Install and tighten the spark plug to the correct torque. For gap and torque specifications, refer to the **Specifications** section.

Servicing the Exhaust System



WARNING During operation, the engine and muffler become hot. If you touch a hot engine, thermal burns can occur.

Combustible materials, such as leaves, grass and brush, can catch fire.

- Before you touch the engine or muffler, stop the engine and wait two (2) minutes. Make sure that the engine and muffler are safe to touch.
- Remove debris from the muffler and engine.

It is a violation of California Public Resource Code, Section 4442, to use or operate the engine on any forest-covered, brush-covered, or grass-covered land unless the exhaust system is equipped with a spark arrester, as defined in section 4442, maintained in effective working order. Other states or federal jurisdictions may have similar laws; reference Federal Regulation 36 CFR Part 261.52. Contact the original equipment manufacturer, retailer, or dealer to obtain a spark arrester designed for the exhaust system installed on this engine.

Remove debris from the muffler and cylinder area. Inspect the muffler for cracks, corrosion, or other damage. Remove the deflector or the spark arrester, if equipped, and inspect for damage or carbon blockage. If damage is found, install the replacement parts before you operate the equipment.

Change Engine Oil



WARNING Fuel and its vapors are flammable and explosive. Fire or explosion could result in burns or death.

During operation, the engine and muffler become hot. If you touch a hot engine, thermal burns can occur.

- If you drain the oil from the top oil fill tube, the fuel tank must be empty. If it is not empty, fuel leakage can occur and cause a fire or an explosion.
- Before you touch the engine or muffler, stop the engine and wait two (2) minutes. Make sure that the engine and muffler are safe to touch.

Used oil is a hazardous waste product and must be discarded of correctly. Do not discard with household waste. Contact your local authorities, service center, or dealer for safe disposal or recycling facilities.

Remove Oil

1. With the engine OFF but warm, disconnect the spark plug wire(s) (D, Figure 9), and keep it away from the spark plugs (E).
2. Remove the dipstick (A, Figure 10).

Quick Oil Drain, if installed

1. Disconnect the quick oil drain hose (H, Figure 11) from the side of the engine.
2. Turn and remove the oil drain cap (I, Figure 11). Carefully lower the quick oil drain (H) into an approved container (J).
3. After the oil has drained, install the quick oil drain cap (I, Figure 11). Attach the quick oil drain hose (H) to the side of the engine.

Change the Oil Filter

1. Drain the oil from the engine. Refer to the **Remove Oil** section.
2. Remove the oil filter (H, Figure 12) and discard correctly.
3. Before you install the new oil filter, lightly lubricate the oil filter gasket with clean oil.
4. Install the oil filter by hand until the gasket touches the oil filter adapter, then tighten the oil filter 1/2 to 3/4 turns.
5. Add oil. Refer to the **Add Oil** section.
6. Start and operate the engine. When the engine is warm, do a check for oil leaks.
7. Stop the engine. Make sure that oil level is at the top of the full indicator on the dipstick. Refer to the **Add Oil** section.

Add Oil

- Make sure the engine is level.
- Clean the oil fill area of all debris.
- Refer to the **Specifications** section for oil capacity.

1. Remove the dipstick (A, Figure 1). Remove oil from the dipstick with a clean cloth.
2. Slowly add oil into the engine oil fill (C, Figure 1). **Do not put too much oil in the engine oil fill.** Wait one minute and then check the oil level.

NOTE: Do not add oil at the quick oil drain, if equipped.

3. Install and tighten the dipstick (A, Figure 1).
4. Remove the dipstick and check the oil level. The correct oil level is at the top of the full indicator (B, Figure 1) on the dipstick.
5. Install and tighten the dipstick (A, Figure 1).
6. Connect the spark plug wire(s) to the spark plug(s). See **Remove Oil** section.

Servicing the Air Filter



WARNING Fuel vapors are flammable and explosive. Fire or explosion could result in burns or death.

- Do not start and operate the engine with the air cleaner assembly (if equipped) or the air filter (if equipped) removed.

NOTICE

Do not use pressurized air or solvents to clean the filter. Pressurized air could result in damage to the filter and solvents will dissolve the filter.

See the **Maintenance Schedule** for servicing requirements.

Different models will use a foam or a paper filter. Some models could also have an optional pre-cleaner that can be cleaned and used again. Compare the illustrations in this manual with the type installed on your engine and service as follows.

Paper Air Filter (with pre-cleaner)

1. Loosen the fastener(s) (A, Figure 13).
2. Remove the air filter cover (B, Figure 13).
3. Remove the filter (C, Figure 13) and the pre-cleaner (D), if installed.
4. To loosen unwanted material, lightly tap the filter on a hard surface. If the filter is dirty, replace it with a new filter.
5. Clean the pre-cleaner (D, Figure 13), if installed, in liquid detergent and water. Let the pre-cleaner fully air dry. **DO NOT** lubricate the pre-cleaner.
6. Assemble the dry pre-cleaner (D, Figure 13), if installed, and the filter (C) into the air filter base (E).
7. Install the air filter cover (B, Figure 13) and attach with fastener(s) (A). Make sure that the fastener(s) is tight.

Servicing the Cooling System



WARNING During operation, the engine and muffler become hot. If you touch a hot engine, thermal burns can occur.

Combustible debris, such as leaves, grass, and brush can catch fire.

- Before you touch the engine or muffler, stop the engine and wait two (2) minutes. Make sure that the engine and muffler are safe to touch.
- Remove debris from the muffler and engine.

NOTICE

Do not use water to clean the engine. Water could cause contamination of the fuel system. Use a brush or dry cloth to clean the engine.

This is an air cooled engine. Dirt or debris can prevent air flow and cause the engine to become too hot and result in unsatisfactory performance and decreased engine life.

1. Use a brush or dry cloth to remove debris from the air intake grille.
2. Keep linkage, springs, and controls clean.
3. Keep the area around and behind the muffler, if equipped, free of combustible debris.
4. Make sure the oil cooler fins, if equipped, are clean.

After a period of time, the cylinder cooling fins can collect debris and cause the engine to overheat. This unwanted material cannot be removed without partial disassembly of the engine. Have a Briggs & Stratton Authorized Service Dealer inspect and clean the air cooling system as recommended in the **Maintenance Schedule**.

Storage

Fuel System

Refer to Figure: 14.



WARNING Fuel and its vapors are flammable and explosive. Fire or explosion could result in burns or death.

Fuel Storage

- Because pilot lights or other ignition sources can cause explosions, keep fuel or equipment away from furnaces, stoves, water heaters or other appliances that have pilot lights.

Keep the engine level (normal operating position). Fill the fuel tank (A, Figure 14) with fuel. For fuel expansion, do not fill above the fuel tank neck (B).

Fuel can become stale when kept in a storage container for more than 30 days. The use of an alcohol-free fuel stabilizer and ethanol treatment in the fuel storage container is recommended to prevent fuel degradation and keep the fuel fresh.

When you fill the fuel container with fuel, add an alcohol-free fuel stabilizer as specified by the manufacturer's instructions. If gasoline in the engine has not been treated with a fuel stabilizer, it must be drained into an approved container. Operate the engine until it is out of fuel.

Engine Oil

While the engine is still warm, change the engine oil. Refer to **Change the Engine Oil** section.

Troubleshooting

Assistance

For assistance, contact your local dealer or go to **BRIGGSandSTRATTON.COM** or call **1-800-444-7774** (in USA).

Specifications

Specifications and Service Parts

MODELS: 44J677, 44X977	
Displacement	49.42 ci (810 cc)
Bore	3.300 in (83,81 mm)
Stroke	2.890 in (73,41 mm)
Oil Capacity	66 - 68 oz (1,9 - 2 L)
Spark Plug Gap	.030 in (.76 mm)
Spark Plug Torque	180 lb-in (180 Nm)
Armature Air Gap	.008 - .012 in (.20 - .30 mm)
Intake Valve Clearance	.004 - .006 in (.10 - .15 mm)
Exhaust Valve Clearance	.004 - .006 in (.10 - .15 mm)

Engine power will decrease 3.5% for each 1,000 feet (300 meters) above sea level and 1% for each 10°F (5.6°C) above 77°F (25°C). The engine will operate satisfactorily at an angle up to 15°. Refer to the equipment operator's manual for safe permitted operating limits on slopes.

MODELS: 44J677, 44X977	
Service Part	Part Number
Air Filter, Paper (See Figure 14)	796031
Air Filter, Pre-Cleaner (See Figure 14)	797704
Oil - SAE 30	100028
Oil Filter	795890
Resistor Spark Plug / EMS	792015
Spark Plug Wrench	19576S
Spark Tester	

We recommend that you see a Briggs & Stratton Authorized Dealer for all maintenance and servicing of the engine and engine parts.

Power Ratings

The gross power rating for individual gasoline engine models is labeled in accordance with SAE (Society of Automotive Engineers) code J1940 Small Engine Power & Torque Rating Procedure, and is rated in accordance with SAE J1995. Torque values are derived at 2600 RPM for those engines with "rpm" called out on the label and 3060 RPM for all others; horsepower values are derived at 3600 RPM. The gross power curves can be viewed at www.BRIGGSandSTRATTON.COM. Net power values are taken with exhaust and air cleaner installed whereas gross power values are collected without these attachments. Actual gross engine power will be higher than net engine power and is affected by, among other things, ambient operating conditions and engine-to-engine variability. Given the wide array of products on which engines are placed, the gasoline engine may not develop the rated gross power when used in a given piece of power equipment. This difference is due to a variety of factors including, but not limited to, the variety of engine components (air cleaner, exhaust, charging, cooling, carburetor, fuel pump, etc.), application limitations, ambient operating conditions (temperature, humidity, altitude), and engine-to-engine variability. Due to manufacturing and capacity limitations, Briggs & Stratton may substitute an engine of higher rated power for this engine.

Warranty

Briggs & Stratton Emissions Warranty

California, U.S. EPA, and Briggs & Stratton, LLC Emissions Control Warranty - Your Warranty Rights and Obligations
For Briggs & Stratton Engine Models with "F" Trim Designation (Model-Type-Trim Representation xxxxxx xxxx Fx)

The California Air Resources Board, U.S. EPA, and Briggs & Stratton (B&S) are pleased to explain the exhaust and evaporative emissions ("emissions") control system warranty on your 2022-2024 engine. In California, new equipment that use small off-road engines must be designed, built, and equipped to meet the State's stringent anti-smog standards. B&S must warrant the emissions control system on your engine/equipment for the periods of time listed below provided there has been no abuse, neglect or improper maintenance of your small off-road engine or equipment leading to the failure of the emissions control system.

Your emissions control system may include parts such as the carburetor or fuel-injection system, the ignition system, catalytic converter, fuel tanks, fuel lines (for liquid fuel and fuel vapors), fuel caps, valves, canisters, filters, clamps and other associated

components. Also included may be hoses, belts, connectors, and other emission-related assemblies.

Where a warrantable condition exists, B&S will repair your engine/equipment at no cost to you including diagnosis, parts, and labor.

Manufacturer's Warranty Coverage:

The exhaust and evaporative emissions control system on your engine/equipment is warranted for two years. If any evaporative emission-related part on your engine/equipment is defective, the part will be repaired or replaced by B&S.

Owner's Warranty Responsibilities:

- As the engine/equipment owner, you are responsible for the performance of the required maintenance listed in your owner's manual. B&S recommends that you retain all receipts covering maintenance on your engine, but B&S cannot deny warranty coverage solely for the lack of receipts or for your failure to ensure the performance of all scheduled maintenance.
- As the engine/equipment owner, you should however be aware that B&S may deny you warranty coverage if your engine/equipment or a part has failed due to abuse, neglect, or improper maintenance or unapproved modifications.
- You are responsible for presenting your engine/equipment to a B&S distribution center or service center as soon as the problem exists. The warranty repairs shall be completed in a reasonable amount of time, not to exceed 30 days. If you have a question regarding your warranty rights and responsibilities, you should contact B&S at 1-800-444-7774 (in USA) or BRIGGSandSTRATTON.COM.

Briggs & Stratton Emissions Control Warranty Provisions

The following are specific provisions relative to your Emissions Control Warranty Coverage. It is in addition to the B&S engine warranty for non-regulated engines found in the Operator's Manual.

1. Warranted Emissions Parts

Coverage under this warranty extends only to the parts listed below (the emissions control systems parts) to the extent these parts were present on the B&S engine and/or B&S supplied fuel system.

a. Fuel Metering System

- Cold start enrichment system (soft choke)
- Carburetor or fuel injection system
- Oxygen sensor
- Electronic control unit
- Fuel pump module
- Fuel line (for liquid fuel and fuel vapors), fuel line fittings, clamps
- Fuel tank, cap and tether
- Carbon canister and mounting bracket
- Pressure relief valves
- Liquid/Vapor separator

b. Air Induction System

- Air cleaner
- Intake manifold
- Purge and vent line

c. Ignition System

- Spark plug(s)
- Magneto ignition system

d. Catalyst System

- Catalytic converter
- Exhaust manifold
- Air injection system or pulse valve

e. Miscellaneous Items Used in Above Systems

- Vacuum, temperature, position, time sensitive valves and switches
- Connectors and assemblies
- Electronic controls

2. Length of Coverage

Coverage is for a period of two years from the date of delivery to an ultimate purchaser, or for the time period listed in the respective engine or product warranty statement, whichever is greater. B&S warrants to the original purchaser and each subsequent purchaser that the engine is designed, built, and equipped so as to conform with all applicable regulations adopted by the Air Resources Board; that it is free from defects in material and workmanship that could cause the failure of a warranted part; and that it is identical in all material respects to the engine described in the manufacturer's application for certification. The warranty period begins on the date the engine or equipment is delivered to an ultimate purchaser.

The warranty on emissions-related parts is as follows:

- Any warranted part that is not scheduled for replacement as required maintenance in the Operator's Manual supplied, is warranted for the warranty period stated above. If any such part fails during the period of warranty coverage, the part will be repaired or replaced by B&S at no charge to the owner. Any such part repaired or replaced under the warranty will be warranted for the remaining warranty period.
- Any warranted part that is scheduled only for regular inspection in the Operator's Manual supplied, is warranted for the warranty period stated above. Any such part repaired or replaced under warranty will be warranted for the remaining warranty period.
- Any warranted part that is scheduled for replacement as required maintenance in the Operator's Manual supplied, is warranted for the period of time prior to the first scheduled replacement point for that part. If the part fails prior to the first scheduled replacement, the part will be repaired or replaced by B&S at no charge to the owner. Any such part repaired or replaced under warranty will be warranted for the remainder of the period prior to the first scheduled replacement point for the part.
- Add-on or modified parts that are not exempted by the Air Resources Board may not be used. The use of any non-exempted add-on or modified parts by the owner will be grounds for disallowing a warranty claim. The manufacturer will not be liable to warrant failures of warranted parts caused by the use of a non-exempted add-on or modified part.

3. Consequential Coverage

Coverage shall extend to the failure of any engine components caused by the failure of any warranted emissions parts.

4. Claims and Coverage Exclusions

Warranty claims shall be filed according to the provisions of the B&S engine warranty policy. Warranty coverage does not apply to failures of emissions parts that are not original equipment B&S parts or to parts that fail due to abuse, neglect, or improper maintenance as set forth in the B&S engine warranty policy. B&S is not liable for warranty coverage of failures of emissions parts caused by the use of add-on or modified parts.

Look For Relevant Emissions Durability Period and Air Index Information On Your Small Off-Road Engine Emissions Label

Engines that are certified to meet the California Air Resources Board (CARB) small off-road Emissions Standard must display information regarding the Emissions Durability Period and the Air Index. Briggs & Stratton makes this information available to the consumer on our emissions labels. The engine emissions label will indicate certification information.

The **Emissions Durability Period** describes the number of hours of actual running time for which the engine is certified to be emissions compliant, assuming proper maintenance in accordance with the Operator's Manual. The following categories are used:

Moderate:

Engines at or less than 80 cc displacement are certified to be emissions compliant for 50 hours of actual engine running time. Engines greater than 80 cc displacement are certified to be emissions compliant for 125 hours of actual engine running time.

Intermediate:

Engines at or less than 80 cc displacement are certified to be emissions compliant for 125 hours of actual engine running time. Engines greater than 80 cc displacement are certified to be emissions compliant for 250 hours of actual engine running time.

Extended:

Engines at or less than 80 cc displacement are certified to be emissions compliant for 300 hours of actual engine running time. Engines greater than 80 cc displacement are certified to be emissions compliant for 500 hours of actual engine running time.

For example, a typical walk-behind lawn mower is used 20 to 25 hours per year. Therefore, the **Emissions Durability Period** of an engine with an **intermediate** rating would equate to 10 to 12 years.

Briggs & Stratton engines are certified to meet the United States Environmental Protection Agency (USEPA) Phase 2 or Phase 3 emissions standards. The Emissions Compliance Period referred to on the Emissions Compliance label indicates the number of operating hours for which the engine has been shown to meet Federal emissions requirements.

For engines at or less than 80 cc displacement:

Category C = 50 hours, Category B = 125 hours, Category A = 300 hours

For engines greater than 80 cc displacement and less than 225 cc displacement:

Category C = 125 hours, Category B = 250 hours, Category A = 500 hours

For engines of 225 cc or more displacement:

Category C = 250 hours, Category B = 500 hours, Category A = 1000 hours

80106345 (Revision A)

Briggs & Stratton Emissions Warranty

California, U.S. EPA, and Briggs & Stratton, LLC Emissions Control Warranty - Your Warranty Rights and Obligations

For Briggs & Stratton Engine Models with "B" or "G" Trim Designation (Model-Type-Trim Representation xxxxxx Bx or xxxxxx Gx)

The California Air Resources Board, U.S. EPA, and Briggs & Stratton (B&S) are pleased to explain the exhaust emissions ("emissions") control system warranty on your 2022-2024 engine. In California, new small off-road engines and large spark ignited engines less than or equal to 1.0 liter must be designed, built, and equipped to meet the State's stringent anti-smog standards. B&S must warrant the emissions control system on your engine for the periods of time listed below provided there has been no abuse, neglect or improper maintenance of your small off-road engine or equipment leading to the failure of the emissions control system.

Your emissions control system may include parts such as the carburetor or fuel-injection system, the ignition system, catalytic converter, fuel tanks, fuel lines (for liquid fuel and fuel vapors), fuel caps, valves, canisters, filters, clamps and other associated components. Also included may be hoses, belts, connectors, and other emission-related assemblies.

Where a warrantable condition exists, B&S will repair your engine at no cost to you including diagnosis, parts, and labor.

Manufacturer's Warranty Coverage:

The exhaust emissions control system on your engine is warranted for two years. If any emissions-related part on your engine is defective, the part will be repaired or replaced by B&S.

Owner's Warranty Responsibilities:

- As the engine owner, you are responsible for the performance of the required maintenance listed in your owner's manual. B&S recommends that you retain all receipts covering maintenance on your engine, but B&S cannot deny warranty coverage solely for the lack of receipts or for your failure to ensure the performance of all scheduled maintenance.
- As the engine owner, you should however be aware that B&S may deny you warranty coverage if your engine or a part has failed due to abuse, neglect, or improper maintenance or unapproved modifications.
- You are responsible for presenting your engine to a B&S distribution center or service center as soon as the problem exists. The warranty repairs shall be completed in a reasonable amount of time, not to exceed 30 days. If you have a question regarding your warranty rights and responsibilities, you should contact B&S at 1-800-444-7774 (in USA) or BRIGGSandSTRATTON.COM.

Briggs & Stratton Emissions Control Warranty Provisions

The following are specific provisions relative to your Emissions Control Warranty Coverage. It is in addition to the B&S engine warranty for non-regulated engines found in the Operator's Manual.

1. Warranted Emissions Parts

Coverage under this warranty extends only to the parts listed below (the emissions control systems parts) to the extent these parts were present on the B&S engine.

a. Fuel Metering System

- Cold start enrichment system (soft choke)
- Carburetor or fuel injection system
- Oxygen sensor
- Electronic control unit
- Fuel pump module

b. Air Induction System

- Air cleaner
- Intake manifold

c. Ignition System

- Spark plug(s)
- Magneto ignition system

d. Catalyst System

- Catalytic converter
- Exhaust manifold
- Air injection system or pulse valve

e. Miscellaneous Items Used in Above Systems

- Vacuum, temperature, position, time sensitive valves and switches
- Connectors and assemblies
- Electronic controls

2. Length of Coverage

Coverage is for a period of two years from the date of delivery to an ultimate purchaser, or for the time period listed in the respective engine or product warranty statement, whichever is greater. B&S warrants to the original purchaser and each subsequent purchaser that the engine is designed, built, and equipped so as to conform with all applicable regulations adopted by the Air Resources Board; that it is free from defects in material and workmanship that could cause the failure of a warranted part; and that it is identical in all material respects to the engine described in the manufacturer's application for certification. The warranty period begins on the date the engine or equipment is delivered to an ultimate purchaser.

The warranty on emissions-related parts is as follows:

- Any warranted part that is not scheduled for replacement as required maintenance in the Operator's Manual supplied, is warranted for the warranty period stated above. If any such part fails during the period of warranty coverage, the part will be repaired or replaced by B&S at no charge to the owner. Any such part repaired or replaced under the warranty will be warranted for the remaining warranty period.
- Any warranted part that is scheduled only for regular inspection in the Operator's Manual supplied, is warranted for the warranty period stated above. Any such part repaired or replaced under warranty will be warranted for the remaining warranty period.
- Any warranted part that is scheduled for replacement as required maintenance in the Operator's Manual supplied, is warranted for the period of time prior to the first scheduled replacement point for that part. If the part fails prior to the first scheduled replacement, the part will be repaired or replaced by B&S at no charge to the owner. Any such part repaired or replaced under warranty will be warranted for the remainder of the period prior to the first scheduled replacement point for the part.
- Add-on or modified parts that are not exempted by the Air Resources Board may not be used. The use of any non-exempted add-on or modified parts by the owner will be grounds for disallowing a warranty claim. The manufacturer will not be liable to warrant failures of warranted parts caused by the use of a non-exempted add-on or modified part.

3. Consequential Coverage

Coverage shall extend to the failure of any engine components caused by the failure of any warranted emissions parts.

4. Claims and Coverage Exclusions

Warranty claims shall be filed according to the provisions of the B&S engine warranty policy. Warranty coverage does not apply to failures of emissions parts that are not original equipment B&S parts or to parts that fail due to abuse, neglect, or improper maintenance as set forth in the B&S engine warranty policy. B&S is not liable for warranty coverage of failures of emissions parts caused by the use of add-on or modified parts.

Look For Relevant Emissions Durability Period and Air Index Information On Your Small Off-Road Engine Emissions Label

Engines that are certified to meet the California Air Resources Board (CARB) small off-road Emissions Standard must display information regarding the Emissions Durability Period and the Air Index. Briggs & Stratton makes this information available to the consumer on our emissions labels. The engine emissions label will indicate certification information.

The **Emissions Durability Period** describes the number of hours of actual running time for which the engine is certified to be emissions compliant, assuming proper maintenance in accordance with the Operator's Manual. The following categories are used:

Moderate:

Engines at or less than 80 cc displacement are certified to be emissions compliant for 50 hours of actual engine running time. Engines greater than 80 cc displacement are certified to be emissions compliant for 125 hours of actual engine running time.

Intermediate:

Engines at or less than 80 cc displacement are certified to be emissions compliant for 125 hours of actual engine running time. Engines greater than 80 cc displacement are certified to be emissions compliant for 250 hours of actual engine running time.

Extended:

Engines at or less than 80 cc displacement are certified to be emissions compliant for 300 hours of actual engine running time. Engines greater than 80 cc displacement are certified to be emissions compliant for 500 hours of actual engine running time.

For example, a typical walk-behind lawn mower is used 20 to 25 hours per year. Therefore, the **Emissions Durability Period** of an engine with an **intermediate** rating would equate to 10 to 12 years.

Briggs & Stratton engines are certified to meet the United States Environmental Protection Agency (USEPA) Phase 2 or Phase 3 emissions standards. The Emissions Compliance Period referred to on the Emissions Compliance label indicates the number of operating hours for which the engine has been shown to meet Federal emissions requirements.

For engines at or less than 80 cc displacement:

Category C = 50 hours, Category B = 125 hours, Category A = 300 hours

For engines greater than 80 cc displacement and less than 225 cc displacement:

Category C = 125 hours, Category B = 250 hours, Category A = 500 hours

For engines of 225 cc or more displacement:

Category C = 250 hours, Category B = 500 hours, Category A = 1000 hours

80111486 (Revision A)

Not for reproduction

Not for reproduction

Not for reproduction

Not for reproduction



Not for reproduction